

總公司：亞洲電材股份有限公司

Headquarter: Asia Electronic Materials Co., Ltd.

////**APLUS** 昆山雅森電子材料科技有限公司

China plant: Kunshan Aplus Tec. Corporation

產品承認書

FOR APPROVAL

客 戶 **SELLER CO.CHOP&AUTHORIZED**

CUSTOMER: _____

品 名 **AHICX015/020/025/125X1MMN**

DESCRIPTION: _____

日 期 **2012-12-13**

DATE: _____

SELLER CO.CHOP&AUTHORIZED:

<i>Approved by</i>	<i>Checked by</i>	<i>Prepared by</i>

Kunshan Aplus Tec. Corporation.

<i>Approved by</i>	<i>Checked by</i>	<i>Prepared by</i>
T.chu	Feilin.Fan	Donglan.Wei

※※※Content※※※



- 1. Application range**
- 2. Product structure**
- 3. Storage condition**
- 4. Quality standard**
 - (1) Physical properties**
 - (2) Electrical properties**
 - (3) Chemical properties**
 - (4) Appearance**
- 5. Test methods**
- 6. Packaging**
- 7. Content of product sticker**
- 8. Lamination conditions**
- 9. Defactive product**

1. Application range

The recognition of the product is offered to [SELLER CO.CHOP&AUTHORIZED](#) by Kunshan Aplus Tec. Corporation, which is about guaranteeing to standardize in quality.

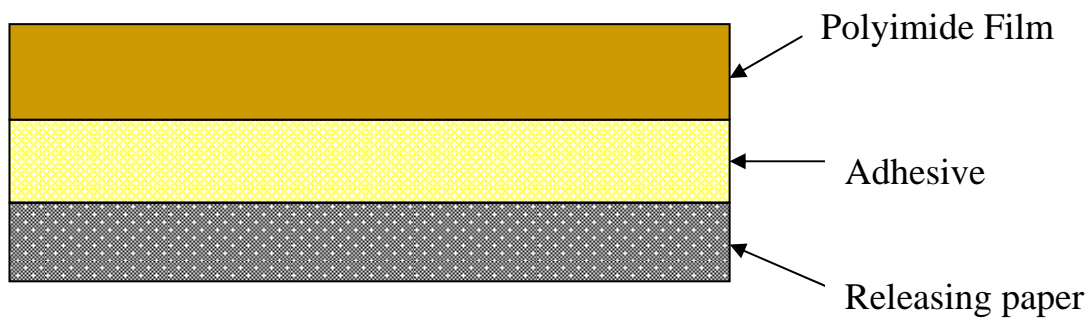
2. Product structure



-  Convectional yellow Polyimide Film , thickness:1/2、 1 mil(12.5、 25um)
-  Epoxy adhesive , thickness: (15、 20、 25um)
-  Releasing paper

3. Storage conditions

3-1 Storage: Store at temperature of below 10°C and below 65% relative humidity.

Guaranteed shelf-life: 3 months in the original producing.

3-2 Storage: Store at temperature of below 5°C and below 65% relative humidity.

Guaranteed shelf-life: 6 months in the original producing.

4. Quality standard

4-1、Physical properties

Test Items		Condition of Treatment	Units	Index of quality	Test method
Thickness	AHICX015	A	μm	27.5±10%	Aplus Spec
	AHICX020			32.5±10%	
	AHICX025			37.5±10%	
	AHICX125			50.0±10%	
Width		A	mm	250±0.5	Aplus Spec
Bow and Twist		A	Cm	Max ≤±3	IPC-TM-650 2.4.22
Releasing Force		A	g/5cm	5~40	Aplus Spec
Peel strength		A	Kgf/cm	≧0.7	IPC-TM-650 2.4.9
Solder Resistance		10 Seconds at 300°C	-	No di-lamination No ain-bubble	IPC-TM-650 2.4.13
Resin Flow		A	mm	≧0.20	IPC-TM-650 2.3.17.1
Dimensional Stability		MD	%	≧±0.20	IPC-TM-650 2.2.4
		TD		≧±0.20	

A: Testing under a regular conditions

4-2、Electrical properties

Test Items	Condition of Treatment	Units	Index of quality	Test method
Surface Resistance	C-96hrs/35°C/90%R.H.	Ω	≧10 ¹²	IPC-TM-650 2.5.17
Volume Resistance	C-96hrs/35°C/90%R.H.	Ω.cm	≧10 ¹⁴	

4-3、Chemical properties

Test Items		Condition of Treatment	Units	Index of quality	Test method
Chemical Resistance	HCL2mol/L Immerse 10mins	----	%	Peel strength reduce ≧20%	IPC-TM-650 2.3.2
	NaOH2mol/L Immerse 10mins	----		Peel strength reduce ≧20%	
	IPA Immerse 10mins	----		Peel strength reduce ≧20%	

4-4、Appearance: If appear the above rejective abnormal phenomena in irregularly, we will offer the discount of 0.5m each abnormal phenomena, and attached Quality Remark Sheet: within 7abnormal phenomena in 200m.

5. Test methods

5-1、Releasing force

(1) Test specimen has a test pattern, such as figure 1

(2) Test process

a. Test conditions: $25\pm 5^{\circ}\text{C}$ $65\pm 20\%\text{RH}$

b. Test speed: 30mm/min

c. Test length: 70mm

d. Test direction: peeling at 180° angle

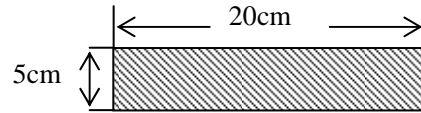

Figure 1: Releasing force test pattern

5-2、Peel strength

(1) Preparation of specimens

a. Placing the coverlay without releasing paper on a smooth surface of copper, then laminate with encapsulation machine (temperature : 50°C , speed: 5rpm)

b. Press bonding conditions:

temperature: $180\pm 5^{\circ}\text{C}$; pressure: $100\text{kgf}/\text{cm}^2$;

pre-press time: 10sec.; press time: 60sec.

c. Postcure conditions: $150^{\circ}\text{C}\times 60\text{min}$.

d. Test specimen has a test pattern, such as figure 2

(2) Test process

a. Test conditions: $25\pm 5^{\circ}\text{C}$ $65\pm 20\%\text{RH}$

b. Test speed: 50.8mm/min

c. Test length: 70mm

d. Test direction: peeling at 90° angle, such as figure 3

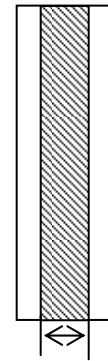

0.3175cm
(copper foil width)

Figure 2: Peel strength test pattern

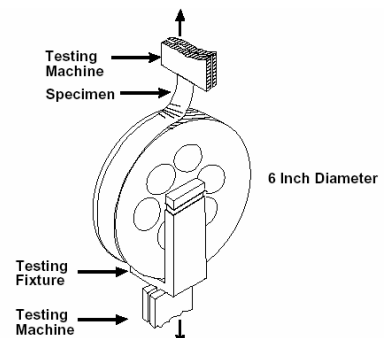

Figure 3: A signal of peeling test

5-3 、 Resin Flow

(1) Preparation of specimens

- a. With the release film intact, punch seven graduating holes (hole diameter:12.7 、 6.4 、 4.8 and 1.6mm) across the coverlay (see figure 4)
- b. Placing the coverlay without releasing paper on the smooth surface of copper, then laminated with encapsulation machine. (temperature :50℃, speed: 5rpm)
- c. Press bonding conditions:
temperature: $180\pm 5^{\circ}\text{C}$; pressure: $100\text{kgf}/\text{cm}^2$; Pre-press time:10sec. Press time: 60sec.

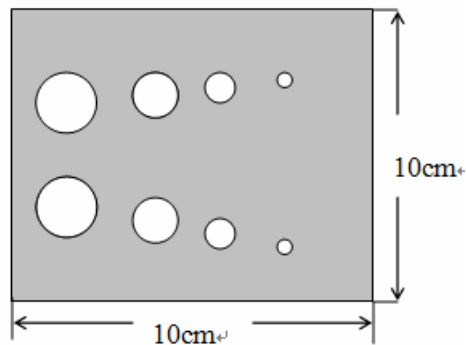

Figure 4: Test pattern for resin flow measurement

(2) Test process

- a. Photo Microscope
- b. Test conditions: $25\pm 5^{\circ}\text{C}$ 65±20%RH
- c. Observation : observe the resin flow situation of adhesive with microscope
Account resin flow: measuring and record the hole's (each hole) resin flow of adhesive, averaging the minimum and maximum resin flow for each hole, finally resin reflow be accounted by 4 hole's averaging resin flow (different diameter).

5-4 、 Dimensional stability

(1) Preparation of specimens

Preparing the specimens such as figure 5

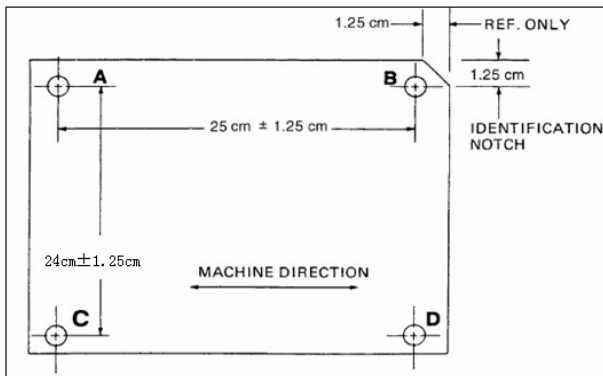

Figure 5: Test pattern of dimensional stability

(2) Test process

a. Test instrument: Two dimension X-Y table

b. Test conditions: $25 \pm 5^\circ\text{C}$ $65 \pm 20\% \text{RH}$

c. Test steps:

1. Punch holes (hole diameter is 4mm) at positions A through D in specimen at locations show in figure 5.
2. Measure separation of holes between corresponding positions (center of holes).For example,The distance between hole centers A-B and C-D, also A-C and B-D. Record as initial measurement (I).
3. Remove the releasing paper, allow specimen to stabilize under usually atmosphere for 20 minutes.
4. Re-measure separation of holes and record as final measurement (F)
5. Calculate the dimensional changes as follow formula:

$$MD(\%) = \frac{\frac{AB_F - AB_I}{AB_I} + \frac{CD_F - CD_I}{CD_I}}{2} \times 100\% ; TD(\%) = \frac{\frac{AC_F - AC_I}{AC_I} + \frac{BD_F - BD_I}{BD_I}}{2} \times 100\%$$

Note: MD=% dimension change in machine direction; TD=% dimension change in transverse direction
I= Initial reading; F= Final reading.

5-5 Surface resistance and volume resistance

(1) Preparation of specimens

- a. Prepare a 10cm × 10cm coverlay that laminated with copper foil, then fully etched out the

copper foil by etching solution. The test pattern of specimen, such as figure 6.

- b. Using water to clean the coverlay specimen then wipe off water and baking 10mins at 100⁰C for fully drying.
- c. Before testing, put the specimen under 35±2⁰C, 90±5%R.H. condition for 96hrs

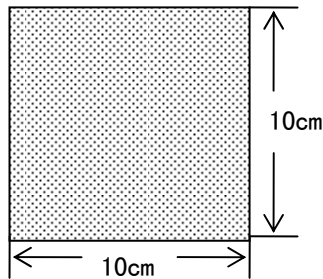

Figure6: Test pattern of volume and surface resistivity

(2) Test process

- a. Test instrument: High resistance meter
- b. Test conditions: 25±5⁰C 65±20%RH
- c. Test steps:
 1. Turn on the megohm meter and allow to warming up for 15 minutes.
 2. After warm up, calibrate meter and adjust charge voltage to 500 volts DC. Switch the adjustment button to select surface or volume resistivity testing mode.
 3. Read the resistivity value on the meter after the voltage (500 volts) charge for 60 seconds.

5-6 Solder resistance

(1) Preparation of specimens

- a. Placing the coverlay without releasing paper on the CCL, then laminated with encapsulation machine. (temperature:50⁰C, speed: 5rpm)
- b. Press bonding conditions:

Temperature: 180±5⁰C; Pressure: 100kgf/cm²;

Pre-press time: 10sec. Press time: 60sec.
- c. Post-cure will be done after laminated. Post-cure conditions: 150⁰C×60min.

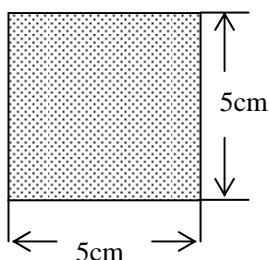

Figure 7: test pattern for soldering resistance

(2) Test process

- a. Test instrument: High temperature soldering bath.
- b. Test conditions: $25\pm 5^{\circ}\text{C}$ $65\pm 20\%\text{RH}$
- c. Test steps:

Immersing the specimens which has a testing pattern(test pattern is $5\text{cm}\times 5\text{cm}$, such as figure in the solder bath and floating for 10 seconds ,then visual viewing for blistering 、 crack 、 de-lamination or wrinkle and record phenomenon.

5-7 Chemical resistance

(1) Preparation of specimens

- a. Placing the coverlay without releasing paper on a smooth surface of copper, then laminate with encapsulation machine (temperature : 50°C , speed: 5rpm)
- b. Press bonding conditions:
temperature: $180\pm 5^{\circ}\text{C}$; pressure: $100\text{kgf}/\text{cm}^2$;
pre-press time:10sec.; press time: 60sec.
- c. Postcure conditions: $150^{\circ}\text{C}\times 60\text{min}$.

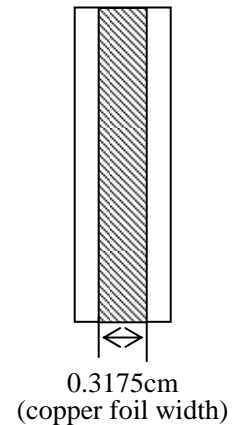

Figure 2: Peel strength test pattern

- d. Test specimen has a test pattern, such as figure 2.The specimen has a 0.3175cm (width) copper strip and total specimen width is 1.5cm. Finally, the specimen will be immersed in HCl 、 NaOH and IPA for 10 mins then wash out chemicals with water and wipe off water for testing.

(2) Test process

- a. Test conditions: $25\pm 5^{\circ}\text{C}$ $65\pm 20\%\text{RH}$
- b. Test speed: 50.8mm/min
- c. Test length: 70mm
- d. Test direction: peeling at 90° angle, such as figure 3

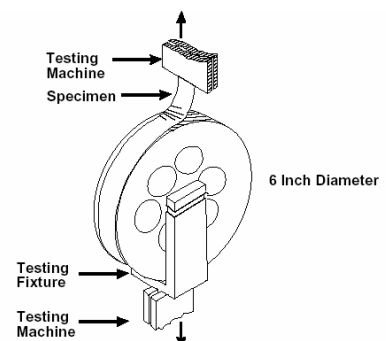

Figure 3: A signal of peeling test

6. Packaging

Item	Specification
Width	Standard width is 250mm,can slitting in different width as customer's require.
Roll	200m/roll
Maximum number of splices	Within 7/roll
Packaging	<ol style="list-style-type: none"> Put the product with drying agent in PE bag, then vacuum sealed. Seal the seam with adhesive tape, then use releasing roll and paper to over 2 side, at last put the roll in carton Stick the shipping mark on the middle of carton's side At last close the carton with adhesive tape
Product sticker	Stick product sticker on each carton
Quality test report	Together with goods of each order

7. Content of product sticker

 坤山電子材料科技有限公司 地址：黃浦江南路169號 Address: Huangpuijiang south road Kunshan Jiangsu Province	
規格/Type	
幅寬/Roll width (mm)	
長度/Roll length (M)	
接頭數/Splice	
製造日期/Produced date	
保質期/Shelf Life	
有效日期/Expiration date	
儲存條件/Storage	
UL型號	
品名/Product Name	
產品批號/Roll No	H.F

8. Lamination condition

8-1、Quickly lamination

Type	Time of Preload (S)	Time of Load (S)	Lamination pressure(Gauge) (kg/cm ²)	Temperature of Lamination (°C)	Curing condition
Single Side	10~20	60~120	100	185±10	160°C*60min
Double Side	10~30	120~180	100	185±10	160°C*60min

8-2、Typical lamination

Condition	Temperature of Load (°C)	Pressure (kg/cm ²)	Time of Load(min)
Heating Period	****	15±5	20~40
Curing Period	165±5°C	25±5	50~90
Cooling Period	****	25±5	30~40

PS: This times and temperature are suggested as a starting point of determining condition suitable for bonding coverlay materials to copper Clad laminate. please note that conditions may vary with the equipment used and circuit design.

9. Handling of Low grade product

9-1、The properties of the products are within the above listed quality specification, the quality of product is up to standard if it meet the specification. We are only in charge of the quality does not conform with the specification.

9-2、Please contact with our salesman or QC Department if there have the other problem in use. If the problem cannot be solved, two parties will consult on the principle of sincerity.

9-3、Please do as our standard of storage conditions and retention period, please confirm with us if storage conditions deviate from the above limits and no guarantee is made.